

Designed & manufactured in Holland

blueSeal[®]

air curtains by **brightec**



blueSeal compact

The most compact air curtain for temperature-controlled transport

The BlueSeal Compact by Brightec features a streamlined design for refrigerated vans, smaller box trucks, vehicles with roller doors and side doors.

BlueSeal Compact is smaller and lighter than its bigger brother the BlueSeal Original. Designed to fit above any rear or side loading door, this compact model features all of the benefits of BlueSeal with a height of only 87mm.

Technical specifications

LENGTH	800MM – 2,430MM (IN INCREMENTS OF 10MM)
HEIGHT	87MM
DEPTH	203MM
MATERIAL	ALUMINIUM (ANODIZED)
FANTYPE	AXIAL
# FANS	28
VOLTAGE	24V AND 12V
ELECTRIC POWER	124W (51W PER METRE)
ELECTRIC CURRENT	5.2A (2.1A PER METRE) - 24V MODEL 9.1A (3.6A PER METRE) - 12V MODEL
POWER CABLE POSITION	RIGHT OR LEFT. FRONT, BACK OR THROUGH SIDE
AIR FLOW	35 M3/MIN. (14.5 M3/MIN. PER METRE)
ENVIRONMENTAL TEMP	-25 TO +50 °C
WEIGHT	12.6 KG (5.2 KG PER METRE)
NOISE	<60 DB (PIEK CERTIFIED BY CEMAFROID)

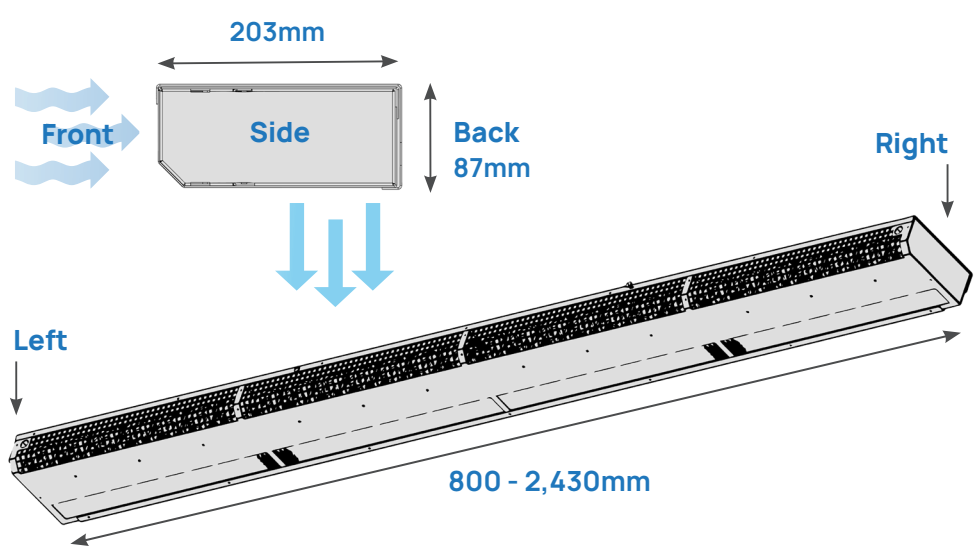

87mm height
BlueSeal Compact fits on the ceiling of any small goods vehicle

No compromise in performance
Despite its thinner design, BlueSeal Compact is just as effective as its counterpart



BlueSeal[®] air curtains are designed and manufactured in the Netherlands by Brightec
For more information visit www.brightec.nl

